

4.1 Introduction

- An **induction motor** or **asynchronous motor** is an AC electric motor in which the electric current in the rotor needed to produce torque is obtained by electromagnetic induction from the magnetic field of the stator winding.
- Three-phase squirrel-cage induction motors are widely used as industrial drives because they are rugged, reliable and economical.
- The induction motor is maintenance free. It has high overloading capacity.
- Single-phase induction motors are used extensively for smaller loads, for household appliances like ceiling fans. Although traditionally used in fixed-speed applications, induction motors are increasingly being used with variable-frequency drives (VFDs) in variable-speed applications like in cranes, lifts, cement plants, ceramic plants, food processing industries etc.
- VFDs offer energy savings opportunities for existing and prospective induction motors in variable-torque centrifugal fan, pump and compressor load applications.

4.2 Construction of Induction Motor

- A three phase Induction motor mainly consists of two parts called as the Stator and Rotor.

(a) Stator

- It is the stationary part of the induction motor.
- The stator is built up of high-grade alloy steel laminations to reduce eddy current losses.
- It has three main parts, outer frame, stator core and a stator winding.

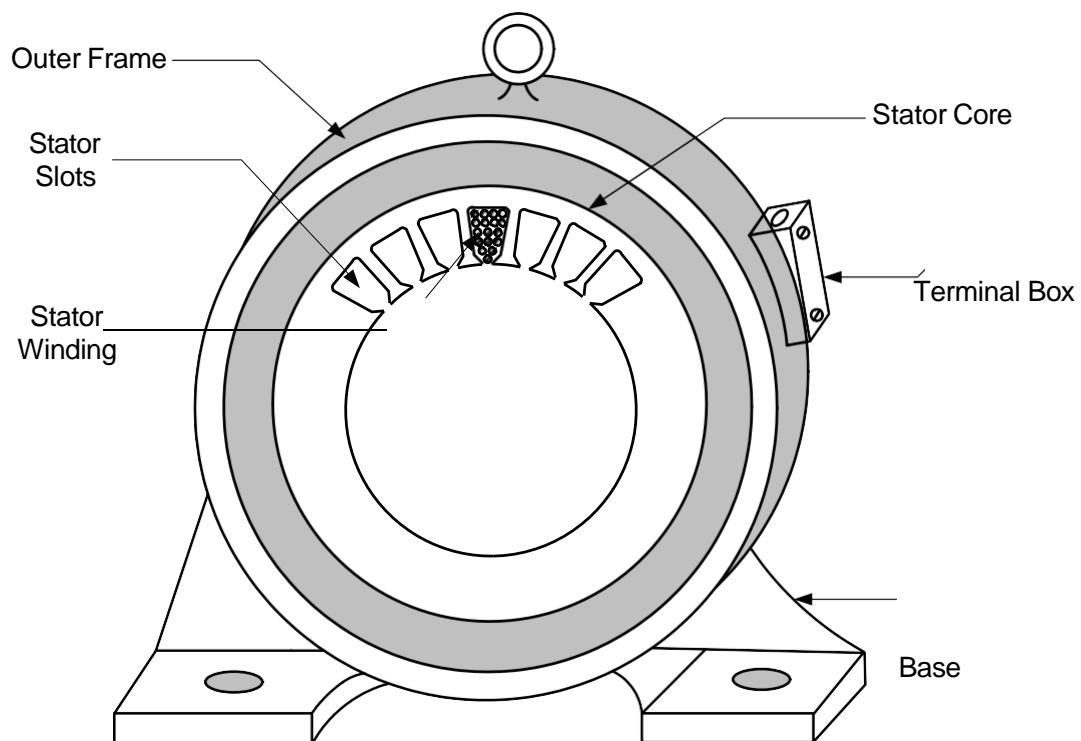

Figure 4.1 Outer frame of an induction motor

- **Outer frame**

4 Electrical Machines

- It is the outer body of the motor. Its main function is to support the stator core and to protect the inner parts of the machine.
-

4 Electrical Machines

- For small machines, the outer frame is casted, but for the large machine, it is fabricated.
- **Stator Core**
 - The core of the stator carries three phase windings which are usually supplied from a three-phase supply system.
 - The stator core is built of high-grade silicon steel stampings.
 - Its main function is to carry the alternating magnetic field which produces hysteresis and eddy current losses.
- **Stator windings**
 - The stator windings are housed in stator slots with double layer winding.
 - These windings are distributed and are mostly short pitched.
 - Anyway, the stator of the motor is wound for a definite number of poles, depending on the speed of the motor.
 - The windings may be connected in star or delta.
 - As the relationship between the speed and the pole of the motor is given as

$$N_s \propto \frac{1}{P} \text{ or } N_s = \frac{120f}{P}$$

(b) Rotor

- It is the rotating part of induction motor
- The rotor is also built of thin laminations of the same material as the stator.
- The laminated cylindrical core is mounted directly on the shaft.
- These laminations are slotted on the outer side to receive the conductors. There are two types of rotor:
 - **Squirrel cage rotor**
 - A squirrel cage rotor consists of a laminated cylindrical core.
 - The circular slots at the outer periphery are semi-closed. Each slot contains uninsulated bar conductor of aluminum or copper.
 - At the end of the rotor the conductors are short-circuited by a heavy ring of copper or aluminum.
 - Now a days this type of motors are widely used in domestic as well as commercial purposes.
 - This type of motors required low maintenance compare to wound rotor type motors.

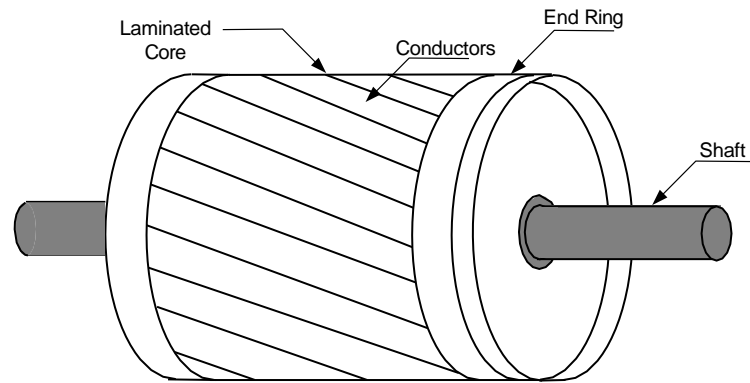

Figure 4.2 Squirrel cage rotor

○ **Wound rotor (Slip ring rotor)**

- A wound rotor is built with a polyphase distributed winding similar to that of stator winding and wound with the same number of poles as, the stator.
- The terminals of the rotor winding are connected to insulated slip rings mounted on the shaft.
- Carbon brushes bearing on these rings make the rotor terminals available external to the motor,
- Wound-rotor induction machines are relatively uncommon, being found only in a limited number of specialized applications.
- This type of motors are widely used where *high starting torque* is required.
- The cost and size of this type motor is more and large respectively.

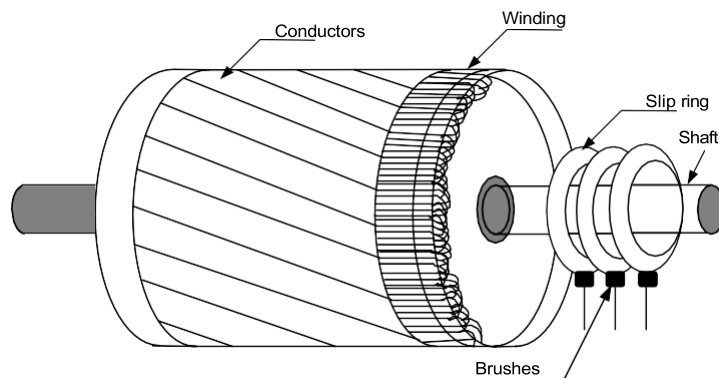

Figure 4.3 Wound rotor

4.3 Production of RMF (Rotating Magnetic Field)

- When stationary three phase winding coils are supplied by an alternating 3-phase supply then uniform Rotating Magnetic Field (or Flux) [RMF] of constant value is produced.
- The principle of a three phase, two pole stator having three identical winding coils are placed by 120° electrical (Space) degree apart. The flux (Sinusoidal) due to three phase windings is shown in below *Figure 4.4 (b)*
- The directions of the positive fluxes are shown individually below at different positions.
- Let us say that the maximum value of the flux due to any one of the three phases be ϕ_m . The resultant flux ϕ_r , at any instant is given by the resultant sum of the individual fluxes ϕ_1 , ϕ_2 and ϕ_3 due to three phases

4 Electrical Machines

- We have consider the 1/6th time period apart corresponding to points marked 0, 1, 2 and 3 in Figure 2.1 (a).

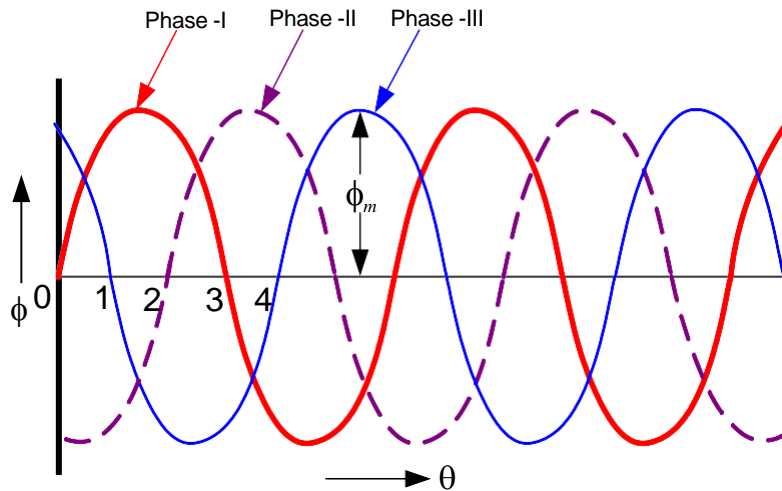

Figure 4.4 (a) Phasor representation

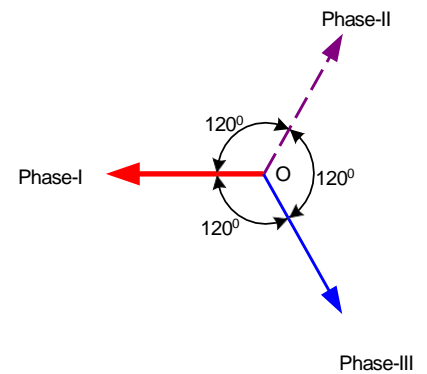

Figure 4.4 (b)

**When $\theta = 0^\circ$
(At point 0)**

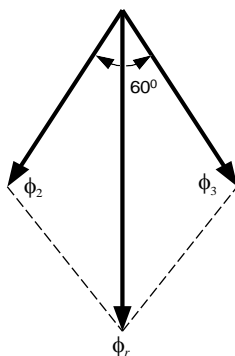

Figure 4.5

**When $\theta = 60^\circ$
(At point 1)**

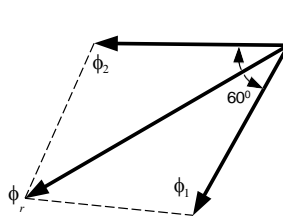

Figure 4.6

**When $\theta = 120^\circ$
(At point 2)**

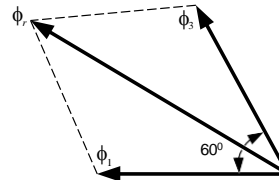

Figure 4.7

**When $\theta = 180^\circ$
(At point 3)**

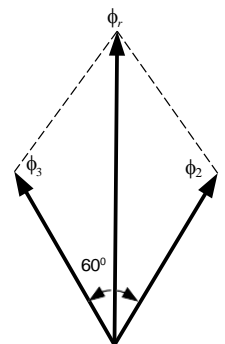

Figure 4.8

$$\begin{aligned} \phi_1 &= 0 \\ \phi_2 &= -\frac{\sqrt{3}}{2} \phi_m \\ \phi_3 &= \frac{\sqrt{3}}{2} \phi_m \end{aligned}$$

$$\begin{aligned} \phi_1 &= \frac{\sqrt{3}}{2} \phi_m \\ \phi_2 &= -\frac{\sqrt{3}}{2} \phi_m \\ \phi_3 &= 0 \end{aligned}$$

$$\begin{aligned} \phi_1 &= \frac{\sqrt{3}}{2} \phi_m \\ \phi_2 &= 0 \\ \phi_3 &= -\frac{\sqrt{3}}{2} \phi_m \end{aligned}$$

$$\begin{aligned} \phi_1 &= 0 \\ \phi_2 &= \frac{\sqrt{3}}{2} \phi_m \\ \phi_3 &= -\frac{\sqrt{3}}{2} \phi_m \end{aligned}$$

4 Electrical Machines

When $\theta = 0^\circ$ Resultant flux,
(At point 0)

$$\begin{aligned} \phi_r &= \sqrt{\phi_2^2 + \phi_3^2 - 2\phi_2\phi_3 \cos\theta} \\ &= \sqrt{\left(\frac{\sqrt{3}}{2}\phi_m\right)^2 + \left(\frac{\sqrt{3}}{2}\phi_m\right)^2 - 2\left(\frac{\sqrt{3}}{2}\phi_m\right)\left(\frac{\sqrt{3}}{2}\phi_m\right) \cos 60^\circ} \\ &= \sqrt{\left[\frac{3}{4} + \frac{3}{4} + 2\left(\frac{1}{2}\right)\right] \phi_m^2} \\ &= \sqrt{\left[\frac{3+3+3}{4}\right] \phi_m^2} \\ &= \sqrt{\left[\frac{9}{4}\right] \phi_m^2} \\ &= \frac{3}{2} \phi_m \end{aligned}$$

When $\theta = 60^\circ$ Resultant flux,
(At point 1)

$$\begin{aligned} \phi_r &= \sqrt{\phi_1^2 + \phi_2^2 - 2\phi_1\phi_2 \cos\theta} \\ &= \sqrt{\left(\frac{\sqrt{3}}{2}\phi_m\right)^2 + \left(\frac{\sqrt{3}}{2}\phi_m\right)^2 - 2\left(\frac{\sqrt{3}}{2}\phi_m\right)\left(\frac{\sqrt{3}}{2}\phi_m\right) \cos 60^\circ} \\ &= \sqrt{\left[\frac{3}{4} + \frac{3}{4} + 2\left(\frac{1}{2}\right)\right] \phi_m^2} \\ &= \sqrt{\left[\frac{3+3+3}{4}\right] \phi_m^2} \\ &= \sqrt{\left[\frac{9}{4}\right] \phi_m^2} \\ &= \frac{3}{2} \phi_m \end{aligned}$$

When $\theta = 120^\circ$
(At point 2) Resultant flux,

$$\phi_r = \sqrt{\phi_1^2 + \phi_3^2 - 2\phi_1\phi_3 \cos\theta}$$

$$= \sqrt{\left(\frac{\sqrt{3}}{2}\phi_m\right)^2 + \left(-\frac{\sqrt{3}}{2}\phi_m\right)^2 - 2\left(\frac{\sqrt{3}}{2}\phi_m\right)\left(-\frac{\sqrt{3}}{2}\phi_m\right) \cos 60^\circ}$$

$$= \sqrt{\left[\frac{3}{4} + \frac{3}{4} + 2\left(\frac{1}{2}\right)\right]\phi_m^2}$$

$$= \sqrt{\left[\frac{3+3+3}{4}\right]\phi_m^2}$$

$$= \sqrt{\left[\frac{9}{4}\right]\phi_m^2}$$

$$= \frac{3}{2}\phi_m$$

When $\theta = 180^\circ$
(At point 3) Resultant flux,

$$\phi_r = \sqrt{\phi_2^2 + \phi_3^2 - 2\phi_2\phi_3 \cos\theta}$$

$$= \sqrt{\left(\frac{\sqrt{3}}{2}\phi_m\right)^2 + \left(-\frac{\sqrt{3}}{2}\phi_m\right)^2 - 2\left(\frac{\sqrt{3}}{2}\phi_m\right)\left(-\frac{\sqrt{3}}{2}\phi_m\right) \cos 60^\circ}$$

$$= \sqrt{\left[\frac{3}{4} + \frac{3}{4} + 2\left(\frac{1}{2}\right)\right]\phi_m^2}$$

$$= \sqrt{\left[\frac{3+3+3}{4}\right]\phi_m^2}$$

$$= \sqrt{\left[\frac{9}{4}\right]\phi_m^2}$$

$$= \frac{3}{2}\phi_m$$

4.4 Working Principle

- For simplicity, consider one conductor on the stationary rotor as shown in *Figure 4.9 (a)*.
- This conductor be subject to the rotating magnetic field produced when a three phase supply is connected to the three phase winding of the stator.
- Consider the rotation of the magnetic field be clockwise.
- A magnetic field moving clockwise has the effect as a conductor moving anticlockwise in a stationary field.
- According to Faraday's law of electromagnetic induction, emf will be produced in the conductor.

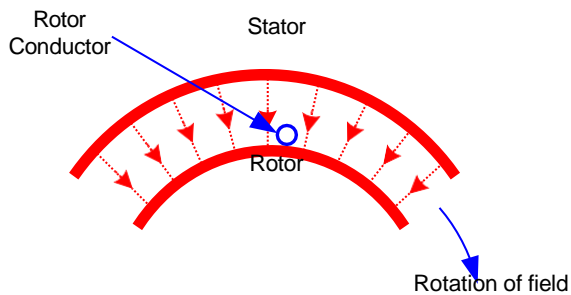

Figure 4.9 (a)

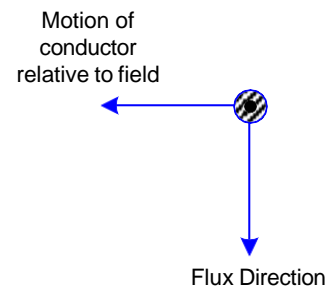

Figure 4.9 (b)

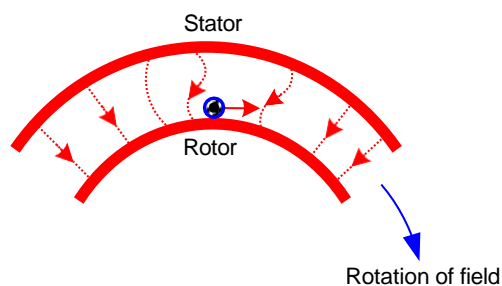

Figure 4.9 (c)

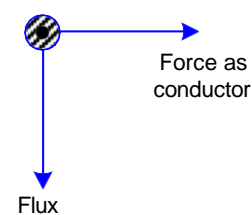

Figure 4.9 (d)

- By completing the rotor circuit either using end rings or external resistances the induced emf causes current to flow in the conductor.
- By using right hand rule we can determine the direction of induced current in the conductor.
- By using right hand rule the direction of the induced current is outwards (shown as dot) in Figure 4.9 (b).
- The current in the rotor conductor produces its own magnetic field as shown in Figure 4.9 (a).
- We know that when a current carrying conductor put in a magnetic field a force is produced. This force is produced on the rotor conductor.
- The direction of this force can be calculated by using left-hand rule as shown in Figure 4.9 (d).
- It is seen that the force acting on the conductor is in the same direction as the direction of the rotating magnetic field.
- The rotor conductor is in a slot on the circumference of the rotor, the force acts in a tangential direction to the rotor and develops a torque in a rotor.
- Similarly, torque produces in all the rotor conductors.
- Since, the rotor is free to move then it rotates in the same direction as the rotating magnetic field. Thus, three phase induction motor is self-starting motor.

4.5 Construction and working of Single phase induction motor:-

- Single phase motors are very widely used in home, offices, workshops etc. as power delivered to most of the houses and offices is single phase.
- In addition to this, single phase motors are reliable, cheap in cost, simple in construction and easy to repair.

- Single phase electric motors can be classified as:
 1. Single phase induction motor (Split phase, Capacitor and shaded pole etc)
 2. Single phase synchronous motor
 3. Repulsion motor etc.

4.6 Single phase Induction motor

○ Construction

- Construction of a single phase induction motor is similar to the construction of three phase induction motor having squirrel cage rotor, except that the stator is wound for single phase supply.
- Stator is also provided with a 'starting winding' and 'running winding'.



Figure 4.10 Single phase induction motor

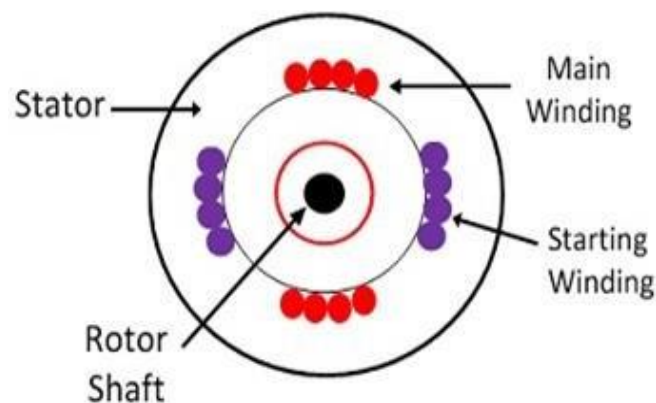

Figure 4.11 Single phase induction motor Construction

○ Working principle of single phase induction motor

- We know that when the stator of a single phase motor is fed with single phase supply, it produces alternating flux in the stator winding.

- The alternating current flowing through stator winding causes induced current in the rotor bars (of the squirrel cage rotor) according to Faraday's law of electromagnetic induction.
- This induced current in the rotor will also produce alternating flux. Even after both alternating fluxes are set up, the motor fails to start (the reason is explained below).
- However, if the rotor is given a initial start by external force in either direction, then motor accelerates to its final speed and keeps running with its rated speed. This behavior of a single phase motor can be explained by double-field revolving theory.

○ Double-field revolving theory

- The double-field revolving theory states that, any alternating quantity (here, alternating flux) can be resolved into two components having magnitude half of the maximum magnitude of the alternating quantity, and both these components rotating in opposite direction.
- Following figures will help you understanding the double field revolving theory.

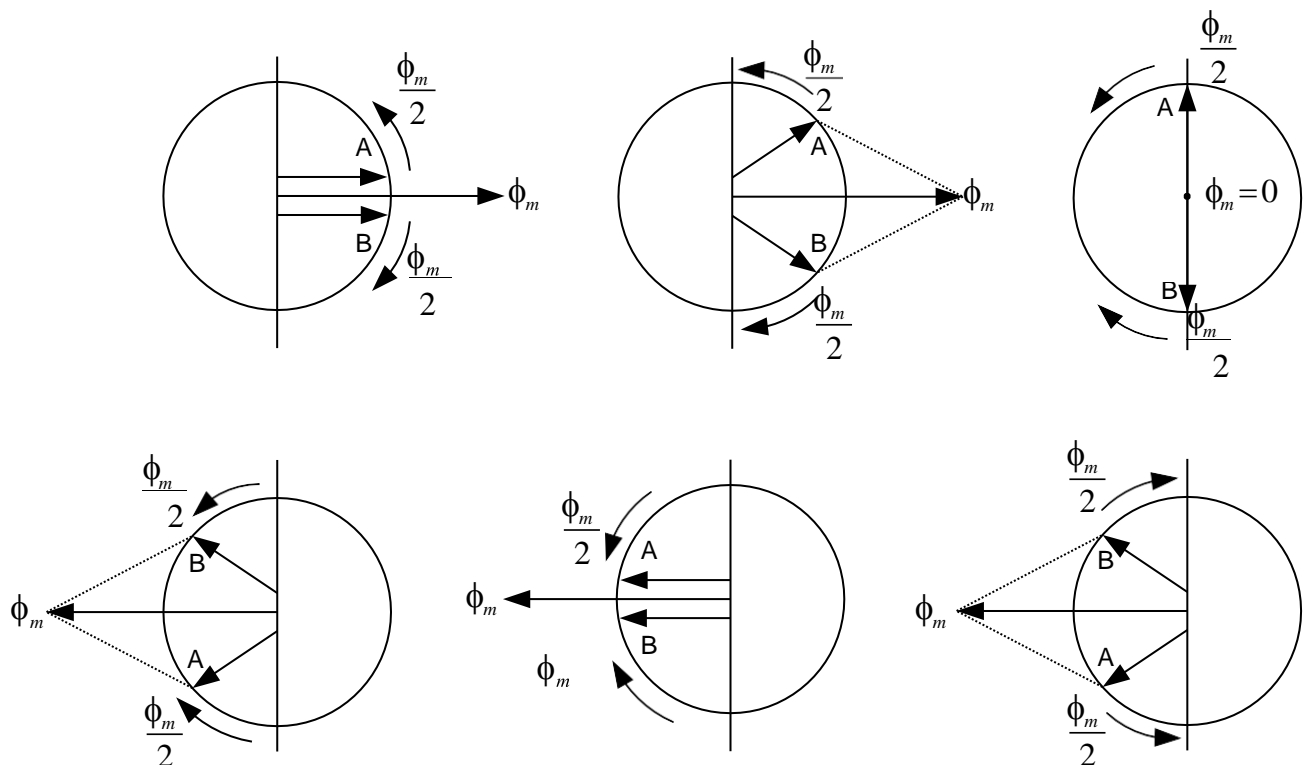

Figure 4.12 Double field revolving theory

4.7 Why single phase induction motor is not self-starting?

- The stator of a single phase induction motor is wound with single phase winding.
- When the stator is fed with a single phase supply, it produces alternating flux (which alternates along one space axis only).
- Alternating flux acting on a squirrel cage rotor cannot produce rotation, only revolving flux can. That is why a single phase induction motor is not self-starting.

4.8 How to make single phase induction motor self-starting?

4 Electrical Machines

- As explained above, single phase induction motor is not self-starting. To make it self-starting, it can be temporarily converted into a two-phase motor while starting.
- This can be achieved by introducing an additional 'starting winding' also called as auxiliary winding.
- Hence, stator of a single phase motor has two windings:
 - Main winding and
 - Starting winding (Auxiliary winding).
- These two windings are connected in parallel across a single phase supply and are spaced 90 electrical degrees apart.
- Phase difference of 90° can be achieved by connecting a capacitor in series with the starting winding.
- Hence the motor behaves like a two-phase motor and the stator produces revolving magnetic field which causes rotor to run.
- Once motor gathers speed, say upto 80 or 90% of its normal speed, the starting winding gets disconnected from the circuit by means of a centrifugal switch, and the motor runs only on main winding.

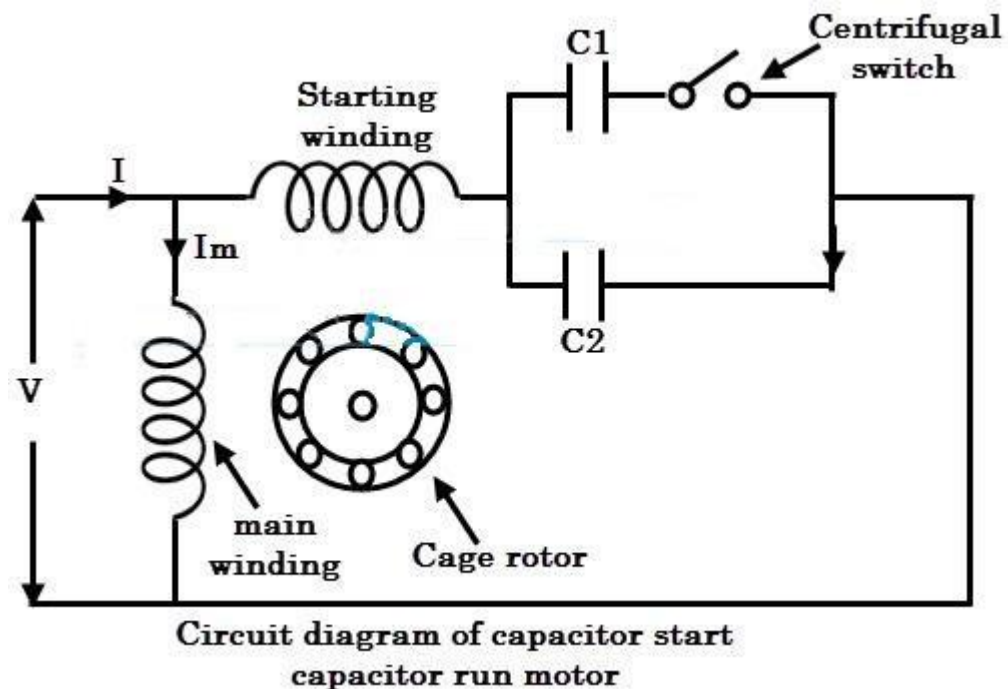

Figure 4.13 Single phase induction motor circuit diagram

- **Applications of Induction motors**
 - Deep Well Water Pumps
 - Refrigerator and Compressors
 - Small water pumps
 - Ceiling fan
 - Washing machines

4.9 DC Motor

DC motors are classified as

- **Separately Excited DC motor**

An extra dc supply or excitation need to start this type of motor.

- **Self-excited DC motor**

No need of extra dc supply to start this type of dc motor

Construction and working of Separately Excited DC motor:

- The DC motor is the device which converts the direct current into the mechanical work. It works on the principle of Lorentz Law, which states that ***“the current carrying conductor placed in a magnetic and electric field experience a force”***. And that force is called the Lorentz force.
- The Fleming’s left-hand rule gives the direction of the force.

4.10 Construction of Separately Excited DC motor

- The construction of DC motor is same as that of DC generator. Construction of DC motor is given below:

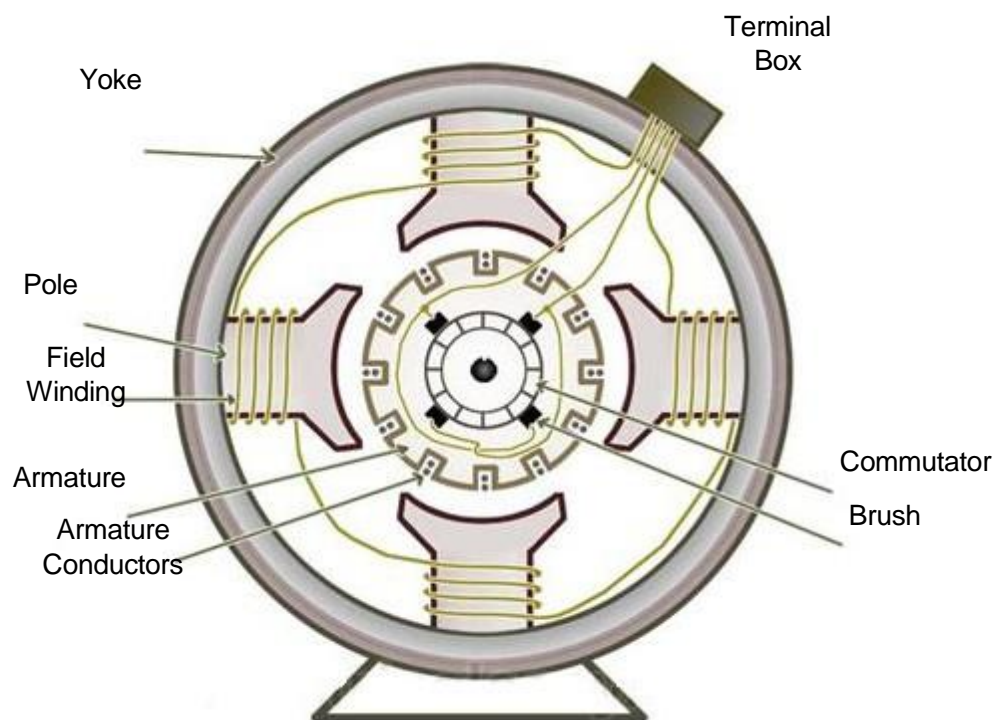

Figure 4.14 Construction of DC motor

Main parts of a DC motor are:

- **Yoke**
- Yoke is also called as frame. It provides the protection to the armature, commutator, windings and other and other parts from moisture and dust.
- It also provide mechanical support to field poles.
- It is made from low reluctance material like cast iron, silicon steel etc.
- For small DC machines it is made from cast iron while for large machines it is made from silicon steel.

4 Electrical Machines

- The steel frame of yoke is affix at the bottom of the frame.
-

○ **Field Winding**

- The winding wound around the poles are known as field winding.
- In this type of motor field winding supplied with extra DC (Excitation).
- The field coils are connected series each other from the field windings.
- The field winding also known as exciting windings and it is made from the pure copper.
- Due to the flow of current through the field winding alternate N and S poles are produced. Which pole is produce at a particular core is decided by the right hand thumb rule for a current carrying circular conductors.

○ **Poles, Pole shoe and Pole core**

- The main parts of the pole are:
- The poles of a DC machine are an electromagnet. The field winding wound on pole.
- Poles produce the magnetic flux when the field winding is excited.
- Pole shoe is the extended curved part of pole and it enlarges the area of pole.
- By curves shape of pole shoe more flux can pass through the air gap to armature.
- A low reluctance magnetic materials are used to made it.
- Poles are made with laminations to reduce the eddy current loss.

○ **Armature**

An armature is the rotating part of DC machine it consists of :

Armature core

- It is the cylindrical part mounted on rotating shaft.
- It is provided with large number of slots all over its periphery and all these slots are parallel with rotating shaft.

Armature windings

- It is usually a former wound copper coil which rests in armature slots.
- The armature conductors are insulated from each other and also from the armature core. Armature winding can be wound by one of the two methods; lap winding or wave winding.
- Double layer lap or wave windings are generally used.
- A double layer winding means that each armature slot will carry two different coils.

○ **Commutator and brushes**

- Physical connection to the armature winding is made through a commutator-brush arrangement.
 - The function of a commutator, in a dc generator, is to collect the current generated in armature conductors. Whereas, in case of a dc motor, commutator helps in providing current to the armature conductors.
 - A commutator consists of a set of copper segments which are insulated from each other.
 - The number of segments is equal to the number of armature coils. Each segment is connected to an armature coil and the commutator is keyed to the shaft.
 - Brushes are usually made from carbon or graphite.
-

4 Electrical Machines

- They rest on commutator segments and slide on the segments when the commutator rotates keeping the physical contact to collect or supply the current.
 - **Bearings**
 - It is provided to reduce friction loss in DC machines.
 - It is mounted on driving end and non-driving end of the shaft.
- **Working of DC motor**
 - **Fleming's Left Hand Rule**
 - The Fleming's left hand rule is used to find out the direction of force acting on the armature conductors of dc motor.
 - If the thumb, middle finger and the index finger of the left hand are displaced from each other by an angle of 90°, the middle finger represents the direction of the magnetic field. The index finger represents the direction of the current, and the thumb shows the direction of forces acting on the conductor.

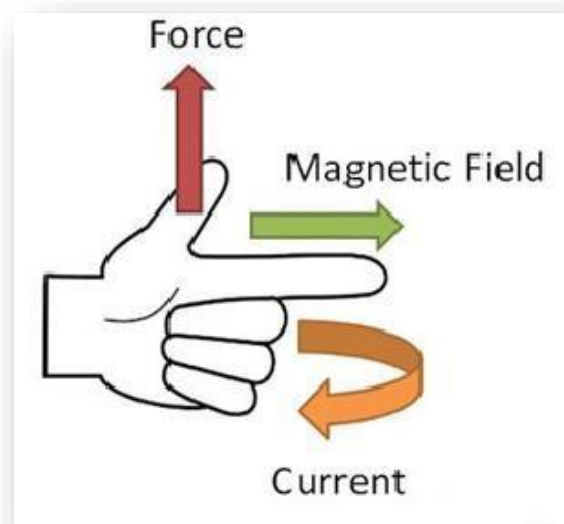

Figure 4.15 Fleming's left hand rule

- The force can be calculated by following formula:
$$F = BIL \text{ (Newton)}$$
 - There is no difference between a dc motor and a dc generator. The same machine we can use as a motor or generator.
 - When the machine is operated as a generator, it is driven by the mechanical machine (prime mover) and it develops voltage which produces a flow of current in an electric circuit.
 - When a machine is operated as a motor, it is supplied electric current and it develops torque (force) which produces mechanical action.
-

○ **Back EMF**

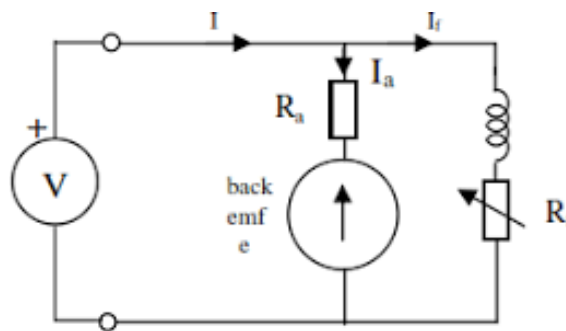

Figure 4.16 DC shunt motor

- When the armature of DC motor rotates, in a magnetic field, armature conductors cut the magnetic flux. Therefore an emf is induced according to Faraday's law of electromagnetic induction in it, whose direction is in the opposition to the applied voltage (according to Len'z law).
- Because of the opposite direction it is called the counter emf or Back emf. It's value is always less than the applied voltage.
- It can be calculated by,

$$E_b = \frac{\phi Z N}{60} \times \left(\frac{P}{A} \right) \text{ Volt}$$
- The applied voltage (V) has to force current through the armature conductors against this back emf.
- The electric work done in overcoming this opposition is converted into mechanical energy developed in the armature.
- Energy conversion is not possible unless there is some opposition. In DC generators, the opposition is provided by magnetic force and in dc motors, back emf does this job.

4.11 Synchronous Generator

Synchronous machines are classified as:

- Synchronous Generator and
- Synchronous motor
- Synchronous generators are widely used to generate constant voltage output, that is why synchronous generators are used in power plants (for examples- Thermal power plants and hydro power plants, Diesel power plants etc.)
- **Construction of Synchronous generator**
- Construction wise, an alternator consists of field poles placed on the rotating fixture of the machine i.e. rotor as shown in the *Figure 4.17* below.
- All modern electrical power generating stations use this technology for generation of three-phase power, and as a result, the alternator or synchronous generator has become a subject of great importance and interest for power engineers.
- An alternator is basically a type of AC generator which also known as synchronous generator. The field poles are made to rotate at synchronous speed $N_s = 120 f/P$ for

effective power generation. Where, f is the alternating current frequency and the P represents the number of poles.

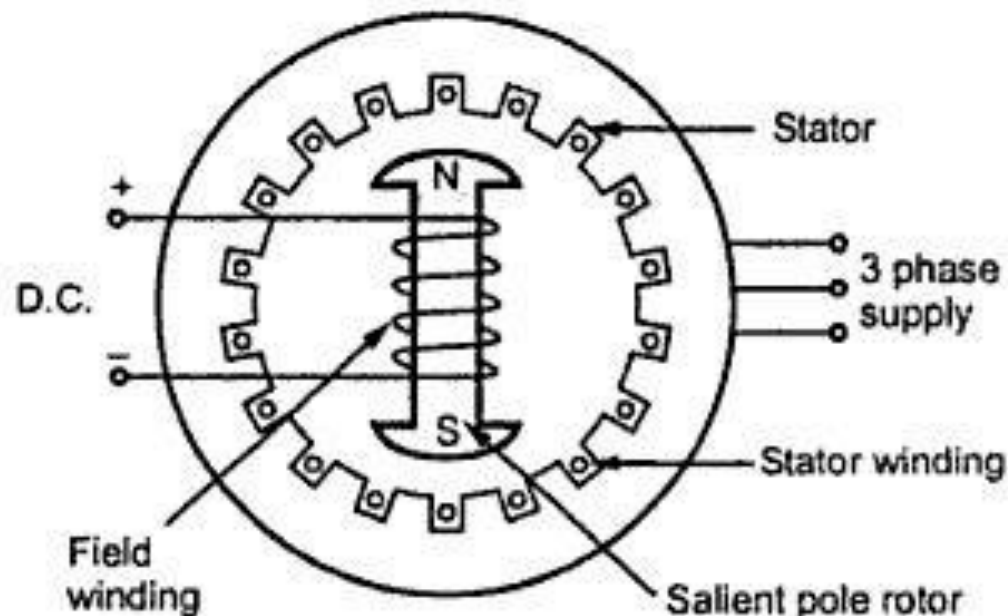

Figure 4.17 Synchronous generator construction

- In most practical construction of alternator, it is installed with a stationary armature winding and a rotating field unlike in the case of DC generator where the arrangement is exactly opposite.
- This modification is made to cope with the very high power of the order of few 100 Megawatts produced in an AC generator contrary to that of a DC generator.
- To accommodate such high power the conductor weighs and dimensions naturally have to be increased for optimum performance.
- For this reason is it beneficial to replace these high power armature windings by low power field windings, which is also consequently of much lighter weight, thus reducing the centrifugal force required to turn the rotor and permitting higher speed limits.
- There are mainly two types of rotor used in construction of alternator,
 - Salient pole type.
 - Cylindrical rotor type.
- **Salient Pole Type**
 - The term salient means protruding or projecting.
 - The salient pole type of rotor is generally used for slow speed machines having large diameters and relatively small axial lengths.
 - The poles, in this case, are made of thick laminated steel sections riveted together and attached to a rotor with the help of joint.

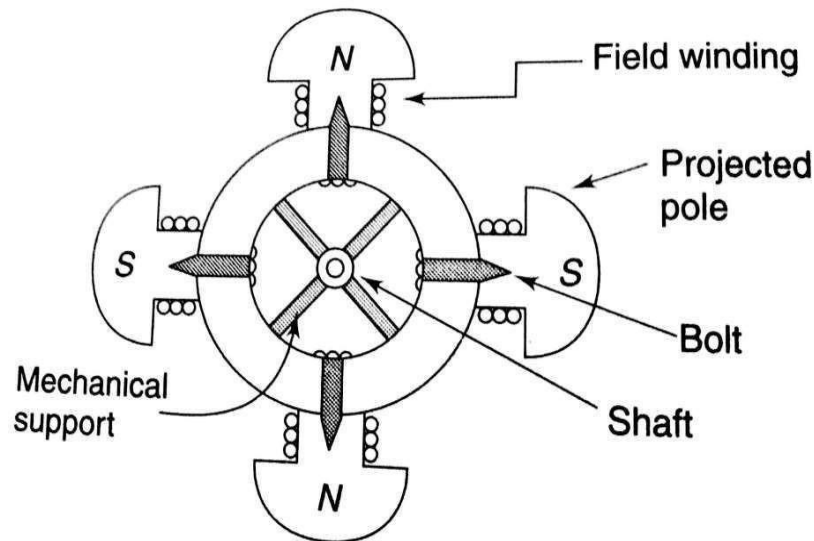

Figure 4.18 Salient pole type rotor

- An alternator as mentioned earlier is mostly responsible for generation of very high electrical power.
- To enable that, the mechanical input given to the machine in terms of rotating torque must also be very high. This high torque value results in oscillation or hunting effect of the alternator or synchronous generator.
- To prevent these oscillations from going beyond bounds the damper winding is provided in the pole faces as shown in the *Figure 4.18*.
- The damper windings are basically copper bars short-circuited at both ends are placed in the holes made in the pole axis.
- When the alternator is driven at a steady speed, the relative velocity of the damping winding with respect to the main field will be zero.
- But as soon as it departs from the synchronous speed there will be relative motion between the damper winding and the main field which is always rotating at synchronous speed.
- This relative difference will induce the current in them which will exert a torque on the field poles in such a way as to bring the alternator back to synchronous speed operation.
- The salient pole type motor is generally used for low-speed operations of around 100 to 400 rpm, and they are used in power stations with hydraulic turbines or diesel engines.
- Salient pole alternators driven by water turbines are called hydro-alternators or hydro generators.
- **Cylindrical Rotor Type**
- The cylindrical rotor is generally used for very high speed operation and employed in steam turbine driven alternators like turbo generators.
- The machines are built in a number of ratings from 10 MVA to over 1500 MVA.

4 Electrical Machines

- The cylindrical rotor type machine has a uniform length in all directions, giving a cylindrical shape to the rotor thus providing uniform flux cutting in all directions.
- The rotor, in this case, consists of a smooth solid steel cylinder, having a number of slots along its outer periphery for hosting the field coils.

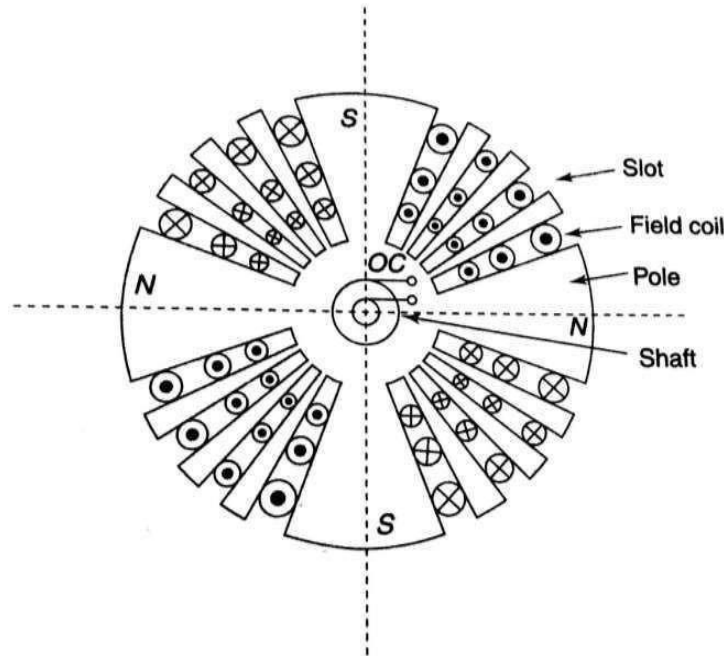

Figure 4.19 Cylindrical Rotor

The cylindrical rotor alternators are generally designed for 2-pole type giving very high speed of

$$N_s = \frac{(120 \times f)}{P} = \frac{(120 \times 50)}{2} = 3000 \text{ rpm}$$

- Where, f is the frequency of 50 Hz. The cylindrical rotor synchronous generator does not have any projections coming out from the surface of the rotor, rather central polar area is provided with slots for housing the field windings as we can see from the diagram above.
- The field coils are so arranged around these poles that flux density is maximum on the polar central line and gradually falls away as we move out towards the periphery.
- The cylindrical rotor type machine gives better balance and quieter-operation along with lesser windage losses.
- **Working Principle of Synchronous generator**
 - Operate on principle of electromagnetic induction
 - Stationary armature and rotating field
 - Rotor is rotated using a prime mover
 - When the rotor rotates, the stationary conductors are cut by the magnetic flux
 - Hence emf is induced in three phase alternators, the rotor flux will induce 3-phase voltages displaced in time by 120° emf induced is AC in nature
 - AC voltage will give rise to AC current when a load is connected to stator

○ **Applications**

- Salient pole generator is used for low speed upto 1000 rpm maximum.
- Salient pole generator is used in hydro-power plant.
- Cylindrical rotor type synchronous generators are high speed machine upto 3000 rpm.
- Cylindrical rotor type synchronous generators are used mostly in thermal power plant.
